

CONDUIT FIXING ACCESSORIES



TECHNICAL CHARACTERISTICS (Engineering plastic versions)

For tube Ø (mm):	16 - 20 - 25 - 32 - 40 - 50
Operating temperature:	-15°C +60°C
Max. operating temperature:	60°C
Halogen free:	Yes
Material:	Engineering plastic
Colour:	Grey RAL 7035

BEHAVIOUR WITH CHEMICAL AND ATMOSPHERIC AGENTS (ENGINEERING PLASTIC VERSIONS)

Saline solution	Acids		Bases		Solvents				Mineral oil	UV rays
	Concentrated	Diluted	Concentrated	Diluted	Hexane	Benzol	Acetone	Alcohol		
Resistant	Limited Resistance	Resistant	Resistant	Resistant	Not Resistant	Not Resistant	Not Resistant	Limited Resistance	Resistant	Resistant

ACCESSORIES FOR RIGID CONDUITS

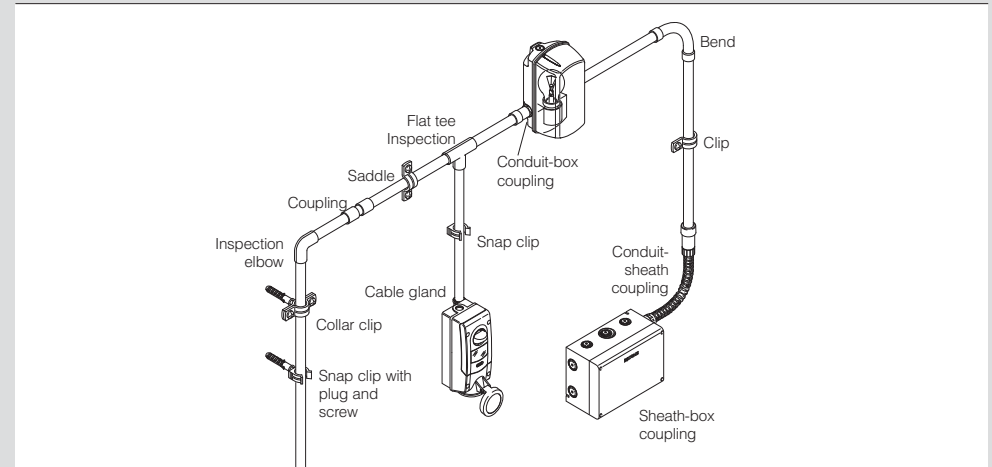

ENGINEERING PLASTIC VERSIONS

	Snap clip
	Snap clip with plug and screw
	Collar clip
	Collar clip
	Pressure clip

METAL VERSIONS

	Spacer bracket with M6 threaded base
	Half-saddle standard type
	Half-saddle heavy duty type
	Saddle

APPLICATION EXAMPLES

