

FICHA DEL PRODUCTO

ITEM:

CÓDIGO:

IMAGEN:



DESCRIPCIÓN
APLICACIÓN:

ESPECIFICACIONES

dimensiones: 172×150×50mm
 Caudal: 319~399m³/hr 188-235CFM
 peso: 870g
 ruido: 52~62dBA
 impulsor: PBT Black
 marco: aleacion de Aluminio
 terminales: 0.5mm
 cable: AWG#22
 Motor: polo sombreado
 temperatura de operacion: -10°C~+70°C

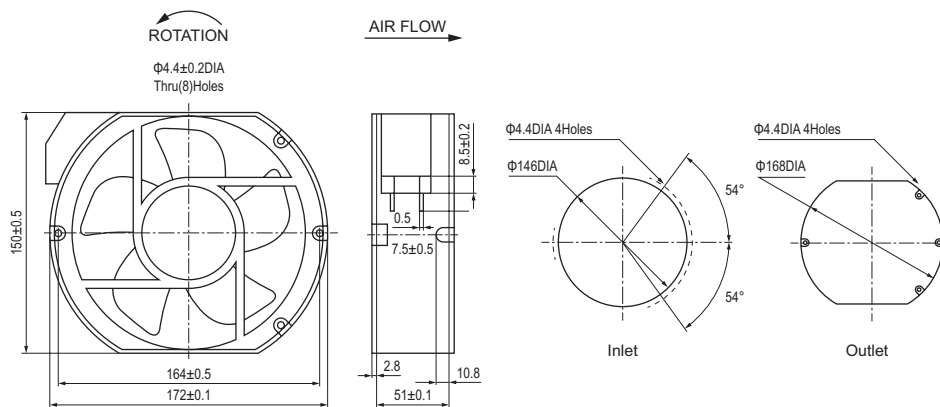
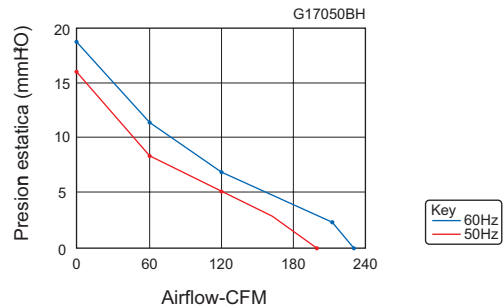

Parametros

Model Number	Bearing Type	Voltage (V)	Freq. (Hz)	Current (A)	Power (W)	Speed (RPM)	Noise (dBA)	Air Flow		Phase	Capacitor
								M ³ /hr	CFM		
51011752FNC	Ball	200~240	50/60	0.43/0.40	26/28	2650/2950	54/50	299/336	176/198	1	/