

Bisagras 180°, atornillables

PROGRAMA 1056

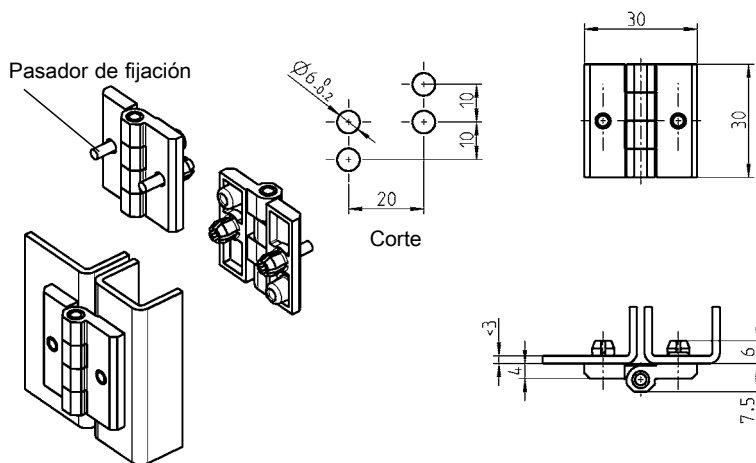

STAINLESS STEEL



Bisagra en poliamida, pasador de fijación y eje en poliamida

1056-U32

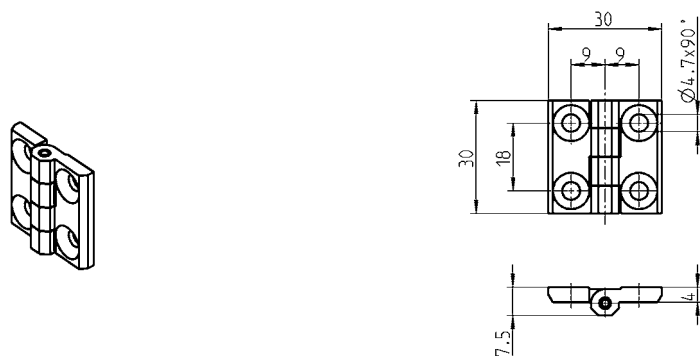

Bisagra, atornillable, en zamak (superficie a elegir), para tornillo avellanado M4, eje en acero inox

negro

1056-U60

cromado

1056-U61

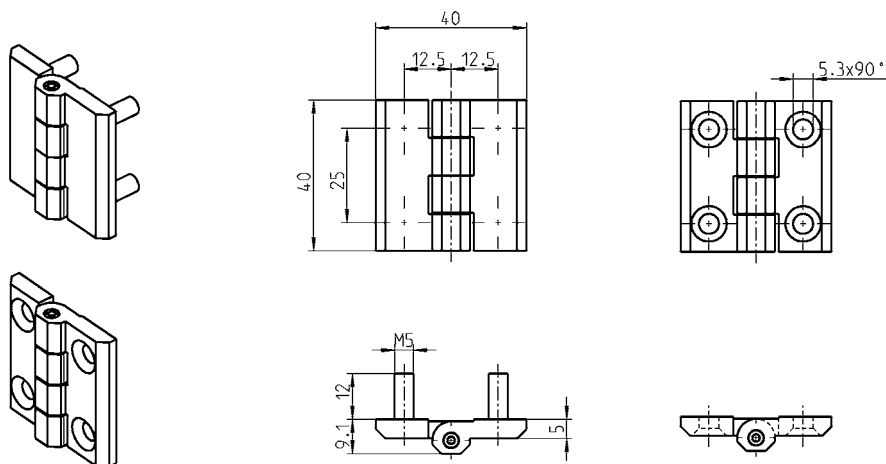

Bisagra, atornillable, en zamak o poliamida o acero inox, perno roscado M5 en acero inox

	Eje	Perno roscado M5	para tornillo avellanado M5
Zamak cromado	Acero inox	1056-U3	1056-U5
Zamak negro	Acero inox	1056-U4	1056-U6
Poliamida negra	Acero inox	-	1056-U30
Poliamida negra	Poliamida	-	1056-U41
AISI 316	Acero inox	-	1056-U5-PH

